

P3 **T9*5*3** **C/P**
Material **Core Size** **Coating**
 材质 品名 涂装

C=Epoxy. P=Parylene.

Dimensions: (UNIT:mm)

Dimensions(mm)			Wt(g/set)
Epoxy Coating Dimensions(mm)			
ΦD1	ΦD2	H	0.6
9.00±0.30	5.00±0.30	3.00±0.20	
10.00 max	4.20 min	3.90 max	

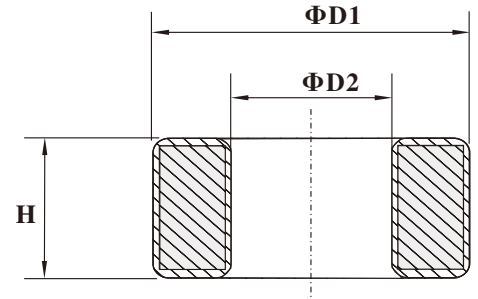
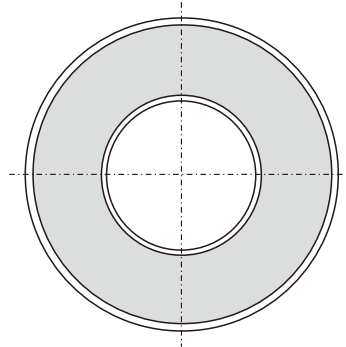

Ferrite core

Test Conditions

AL: F=10.0KHz U=0.3V N=10Ts

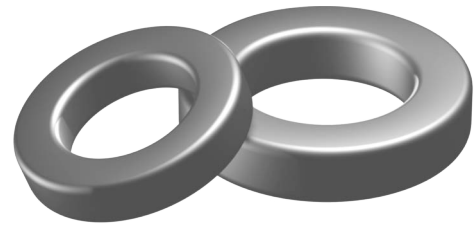

Effective parameter

	Ve(mm3)	Ae(mm2)	Le(mm)
	134	6.1	22.0

Coating

The core are coated with epoxy, flame retardant in accordance with "UL 94V-0" file number E228348. The colour is green.

Ring core data

GRADE	AL(nH)	μi	TYPE NUMBER
P3	850±20%	≈2300	T9/5/3/P3
H5K	1800±20%	≈5000	T9/5/3/H5K
H7K	2500±20%	≈7000	T9/5/3/H7K
H10K	3500±20%	≈10000	T9/5/3/H10K

Note:

- 1: Document is the property of FUAN Inc & is not allowed to be duplicated without authorization
- 2: RoHS compliant.

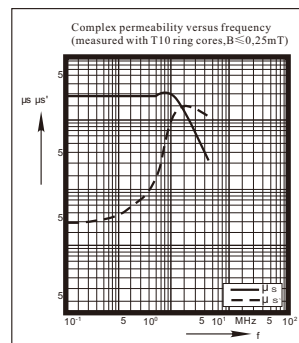

P3

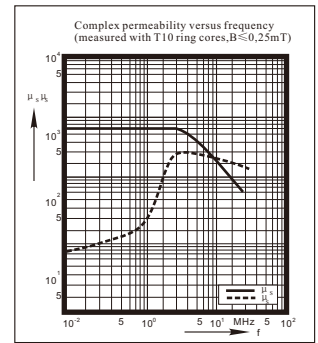

H5K

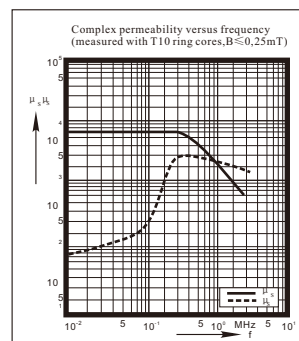

H7K

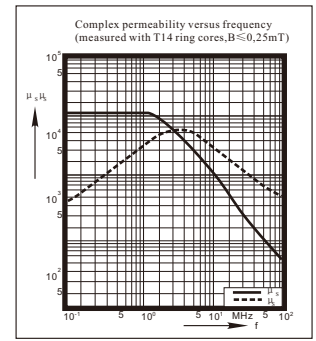

H10K